

CD200M Dri-Prime® Pumps

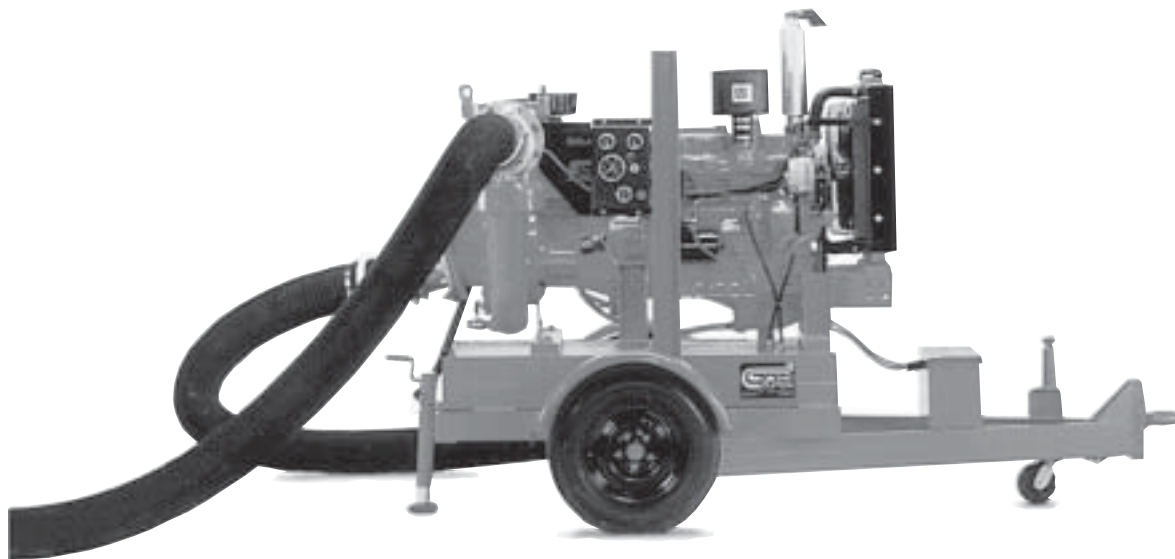

The Godwin Dri-Prime 8" (200mm) CD200M automatic priming centrifugal pump is clearly a standard for the temporary portable pumping industry. With solids-handling to 3" (75mm), maximum flows of 2300 gpm (145 l/sec.) and 170' (51.8M) of total dynamic head, and indefinite dry-running capabilities, the CD200M can be found in a wide variety of applications from straight dewatering to sewage bypassing. Mounted on a highway trailer, the CD200M is both maneuverable and versatile, making it a favorite of contractors, municipalities, industry and environmental companies across the country.

Features

- Close coupled centrifugal pump with vacuum priming compressor mounted to a diesel engine. Also available in electric drive or as bare shaft pumpend.
- All cast iron construction with cast chromium steel impeller.
- Extensive application flexibility — will handle raw sewage, slurries and liquids with solids up to 3" (75mm) in diameter.
- Continuously operated "Godwin" air ejector priming device requiring no periodic adjustment or control.
- Dry running, oil bath, mechanical seal with abrasion-resistant, solid silicon carbide interfaces.
- Solids handling ball type Non Return Valve with renewable flexible rubber seat and quick release access feature.
- Compact unit mounted on skid base or two wheeled highway trailer both incorporating integral overnight running fuel tank.
- Simple maintenance — normally limited to checking engine and seal cavity oil levels.
- Standard engine — John Deere 4045D or Caterpillar 3054NA. Also available with a variety of engines including Hatz and Deutz.
- Critical silence unit available for use in environments requiring minimal noise.

CD200M Performance Curve

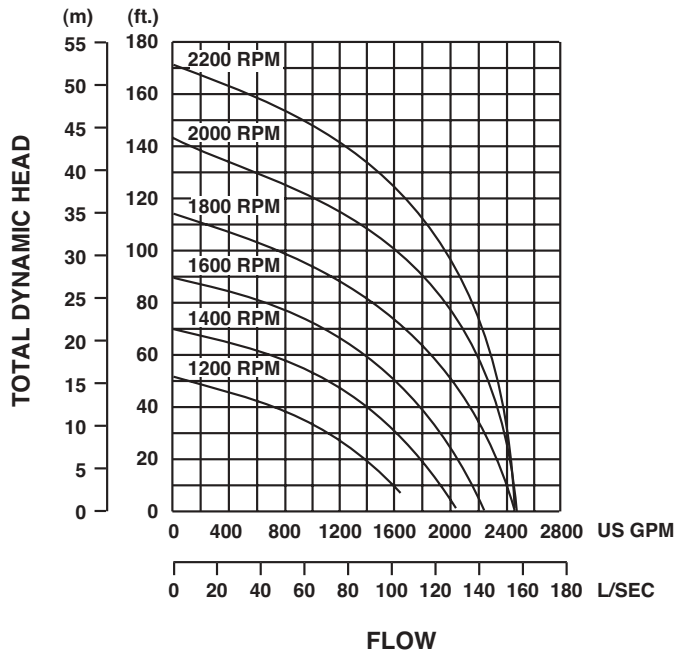

Performance Table

Diesel Set: John Deere 4045D, 71 hp (53 kw) @ 2200 rpm
 Caterpillar 3054NA, 74 hp (55 kw) @ 2200 rpm
 Impeller Diameter: 11.2" (280mm)

Total Suction Head — Feet	Total Delivery Head — Feet			
	60	80	100	120
10	2300	2090	1995	1630
15	2285	2075	1960	1600
20	1940	1855	1785	1560
25	1620	1600	1560	1400

Performance data listed in table and curves are based on water tests at sea level and 68° F (20° C). Larger diameter pipes may be required for maximum flows.

Dimensions

CD200M — John Deere 4045D, GP60 Highway Trailer
 Weight: 3,200 lbs. (1,451.5 kg.)

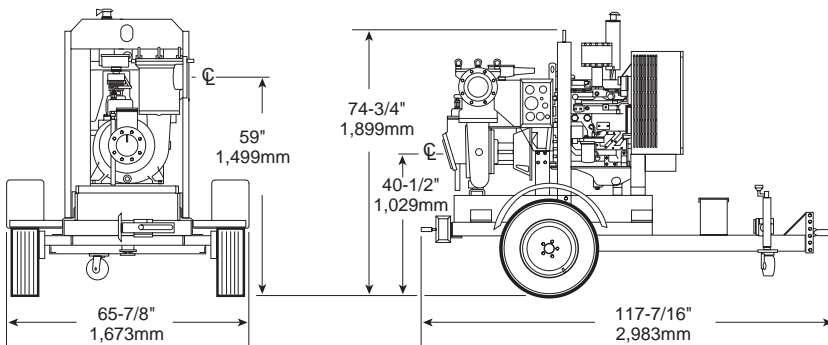

Specifications

- Maximum Operating Speed:** 2200 rpm
- Maximum Operating Temperature:** +212° F (100° C)
- Maximum Working Pressure:** 58.5 psi (4.0 BAR)
- Maximum Suction Pressure:** 40.0 psi (2.8 BAR)
- Maximum Casing Test Pressure:** 88.0 psi (6.1 BAR)
- Fuel Tank Capacity:** 60 to 100 gallons (227 to 378.5 liters)
- Fuel Consumption:** JD 4045D: 3.82 gph (14.46 lph) @ 2200 rpm
CAT 3054NA: 4.3 gph (16.28 lph) @ 2200 rpm
- Pipe Connections:** 8" (200mm) ASA 150#
- Solids Handling:** 3" (75mm) dia., standard impeller

Materials

- Pump Casing, Suction Cover, Separation Tank and Wearplates:** Close grained cast iron
- Impeller:** Cast chromium steel hardened to minimum Brinell 341 HB
- Shaft:** 1-1/2% nickel/chromium steel
- Non Return Valve Body, Ejector Housing:** Close-grained cast iron
- Non Return Valve – Ball and Seat:** High nitrile rubber
- Mechanical Seal Faces:** Solid silicon carbide



One Floodgate Road, Bridgeport, NJ 08014, USA
 (856) 467-3636 • Fax: (856) 467-4841
 Quenington, Cirencester, Glos., GL7 5BX, UK
 +44 (0)1285 750271 • Fax: +44 (0)1285 750352

E-mail: sales@godwinpumps.com
 www.godwinpumps.com

BRANCH LOCATIONS:
 Norwich, CT • Buffalo, NY • Chicago, IL
 Washington, DC • Richmond, VA • Virginia Beach, VA
 Charleston, WV • Raleigh, NC • Charlotte, NC
 N. Charleston, SC • Atlanta, GA • Houston, TX
 San Antonio, TX • Helena, MT • Los Angeles, CA

Dri-Prime® is a registered trademark of Godwin Pumps of America, Inc. Specifications and illustrations are subject to revision without notice. © Copyright 2002 Godwin Pumps of America, Inc.