

CD300M Dri-Prime® Pumps

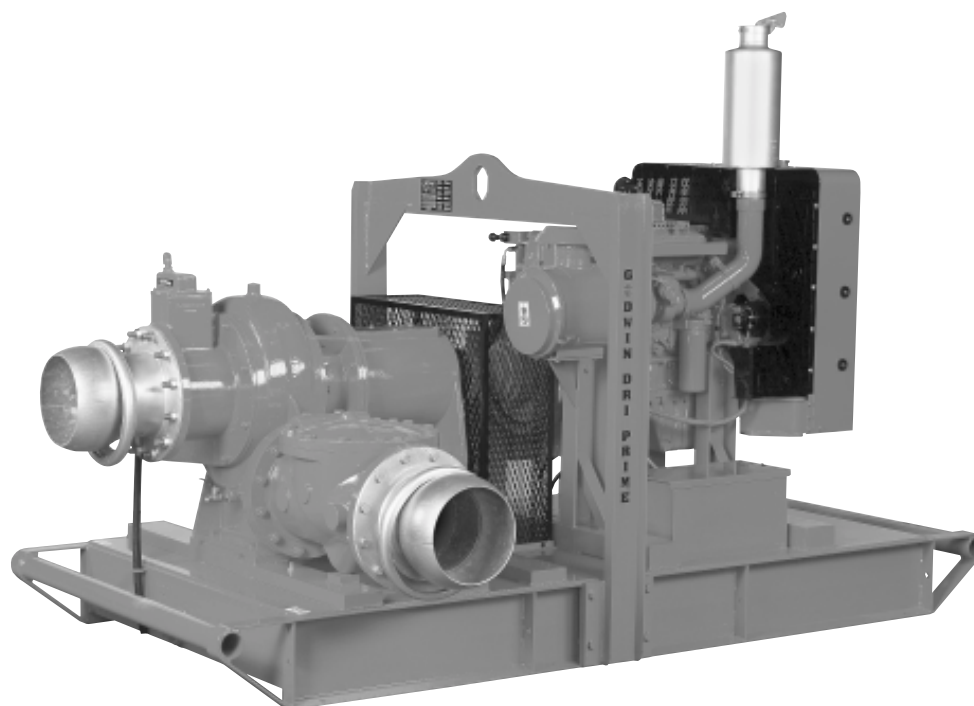

The Godwin CD300M Dri-Prime pump is a 12 inch (300mm) centrifugal trash pump perfect for your biggest jobs. Offering flows to 6,000 gallons per minute (380 liters per second), discharge heads to 200 feet (60 meters), and solids handling to 3-3/4" (95mm) in diameter, the CD300M moves large volumes of water and provides automatic self-priming to 28 feet. For intermittent flows, the double high pressure mechanical seal means the CD300M can run dry indefinitely without damage. And the underslung discharge flange makes pump connections easy and efficient. When your job calls for both high volume and high head, the Godwin CD300M is the pump that does it all.

Features

- Direct drive automatic priming 12" (300mm) high volume centrifugal pump with vacuum priming compressor mounted to a diesel engine. Also available in electric drive or as bare shaft pumpend.
- Extensive application flexibility — handles raw sewage, sludges and liquids with solids up to 3-3/4" (95mm) in diameter.
- Continuously operated "Godwin" air ejector priming device requiring no form of periodic adjustment or control.
- Compact design — Pump is direct coupled to engine flywheel for increased reliability.
- Underslung side discharge for easy pipe connection.
- Double, high pressure mechanical seal with high abrasion resistant silicon carbide interfaces. Oil bath immersion for dry running.
- Skid base incorporating integral overnight running fuel tank.
- Simple maintenance — normally limited to checking engine oil, compressor oil and seal lubrication.
- Standard Caterpillar 3306B, Caterpillar 3126TA or John Deere 6081AF engine. Also available with a variety of other engines including Cummins and Deutz.
- Balanced unit with centralized lifting bracket for easy handling.

CD300M Dri-Prime® Performance Curve

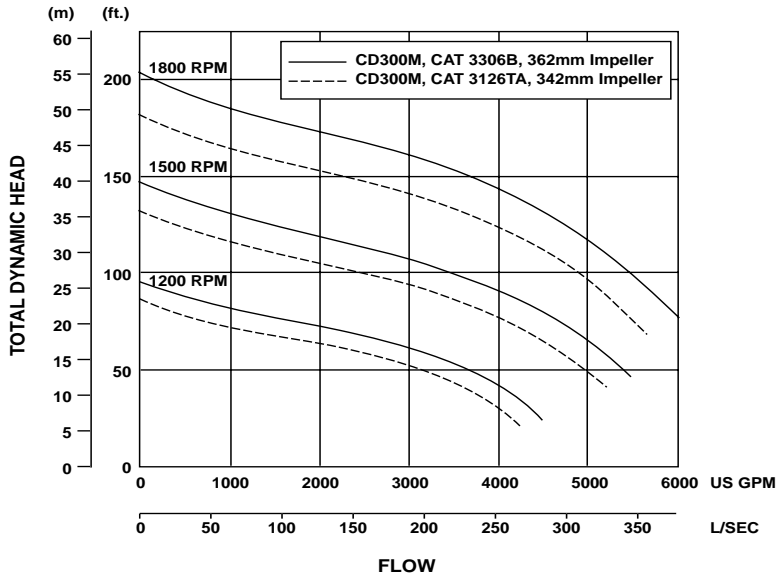

Performance Tables

CD300M with Caterpillar 3306B Diesel Engine, 288 hp @ 1800 rpm
Impeller Diameter: 14-1/4 inches (362 mm)

Total Suction Head — Feet	Total Delivery Head — Feet			
	40	80	120	160
10	6000	5810	4870	3010
15	5480	5250	4700	3000
20	4850	4780	4500	2900
25	4300	4100	3800	2800

CD300M with Caterpillar 3126TA Diesel Engine, 203 hp @ 1800 rpm
Impeller Diameter: 13-1/2 inches (342 mm)

Total Suction Head — Feet	Total Delivery Head — Feet			
	40	80	120	150
10	6000	5400	4180	2390
15	5180	4850	4050	2380
20	4550	4450	3950	2370
25	4050	3800	3400	2360

Performance data listed in table and curves are based on water tests at sea level and 68° F (20° C). Larger diameter pipes may be required for maximum flows.

Dimensions

CD300M — shown with Caterpillar 3306B, Skid Base
 Weight: 11,500 lbs. (5,227 kg.)

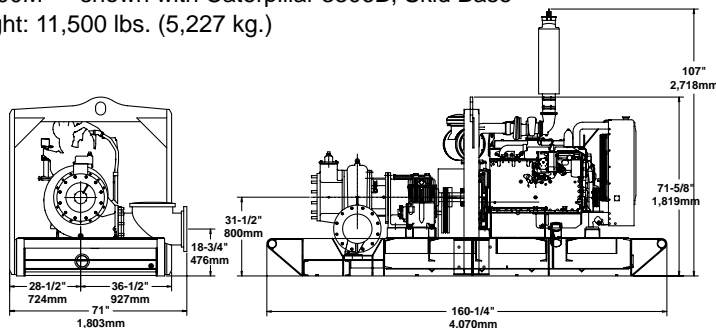

Measurements are approximate. Consult factory for exact dimensions.

Specifications

- Maximum Operating Speed:** 1800 rpm
- Maximum Operating Temperature:** +212° F (100° C)
- Maximum Working Pressure:** 87 psi
- Maximum Suction Pressure:** 88 psi
- Maximum Casing Pressure:** 130 psi
- Fuel Tank Capacity:** 250 gallons (946 litres)
- Fuel Consumption (full load & max. speed):**
 CAT 3306B: 12 gph (45.4 lph) @ 1800 rpm
 CAT 3126TA: 10.2 gph (38.6 lph) @ 1800 rpm
 JD 6081AF: 10.6 gph (40.1 lph) @ 1800 rpm
- Pipe Connections:** 12 inch (300mm) ASA 150#
- Solids Handling:** 3-3/4" (95mm) diameter

Materials

- Pump Casing, Suction Cover, and Separation Tank:** Close Grained Cast Iron
- Impeller:** Nitride Hardened Cast Chromium Steel
- Front Wearplate:** 25% Chromium Iron
- Rear Wearplate:** Nitride Hardened Cast Iron
- Pump Shaft:** 1-1/2% Nickel/Chromium Steel
- Non Return Valve Body Ejector Housing:** Close Grained Cast Iron
- Non Return Valve Flapper:** High Nitrile Rubber
- Mechanical Seal Faces:** Solid Silicon Carbide



One Floodgate Road, Bridgeport, NJ 08014, USA
 (856) 467-3636 • Fax: (856) 467-4841
 Quenington, Cirencester, Glos., GL7 5BX, UK
 +44 (0)1285 750271 • Fax: +44 (0)1285 750352

E-mail: sales@godwinpumps.com
www.godwinpumps.com

BRANCH LOCATIONS:
 Norwich, CT • Buffalo, NY • Chicago, IL
 Washington, DC • Richmond, VA • Virginia Beach, VA
 Charleston, WV • Raleigh, NC • Charlotte, NC
 N. Charleston, SC • Atlanta, GA • Houston, TX
 San Antonio, TX • Helena, MT • Los Angeles, CA

Dri-Prime® is a registered trademark of Godwin Pumps of America, Inc. Specifications and illustrations are subject to revision without notice.
 © Copyright 2002 Godwin Pumps of America, Inc. All rights reserved.
 GPASL.073.602