

CD80M Dri-Prime® Pumps



The Godwin Dri-Prime® 3" CD80M automatic priming centrifugal pump is a compact and highly maneuverable portable pumping system that can deliver a maximum of 450 gallons per minute and total dynamic heads to 93 feet. The CD80M comes standard mounted on a highway trailer or skid mounted, and both include an integral 30 gallon fuel tank for overnight running capabilities. A recessed impeller model is also available for increased solids handling. Indefinite dry running is no problem due to the unique Godwin oil bath mechanical seal design. Solids handling, dry-running and portability make the CD80M the perfect choice for small dewatering and bypass applications.

Features

- Close coupled centrifugal pump with vacuum priming compressor mounted to a diesel engine. Also available in electric drive or as bare shaft pumpend.
- All cast iron construction with cast chromium steel impeller. Also available in 316 stainless steel.
- Extensive application flexibility — will handle raw sewage, sludges and liquids with solids up to 1-5/8" in diameter.
- Continuously operated "Godwin" patented air ejector priming device requiring no form of periodic adjustment or control.
- Dry running, oil bath, mechanical seal with abrasion resistant solid silicon carbide interfaces.
- Solids handling mushroom-type Non-Return Valve with renewable flexible rubber seat and quick release access feature.
- Compact unit mounted on two-wheeled highway trailer or skid base, both incorporating integral overnight running fuel tank.
- Simple maintenance — normally limited to checking engine and seal cavity oil levels.
- Standard engine: John Deere 3009D. Available with a variety of engines including Lister, Hatz, Perkins and Deutz.
- Available with optional silence pack.

CD80M Performance Curve

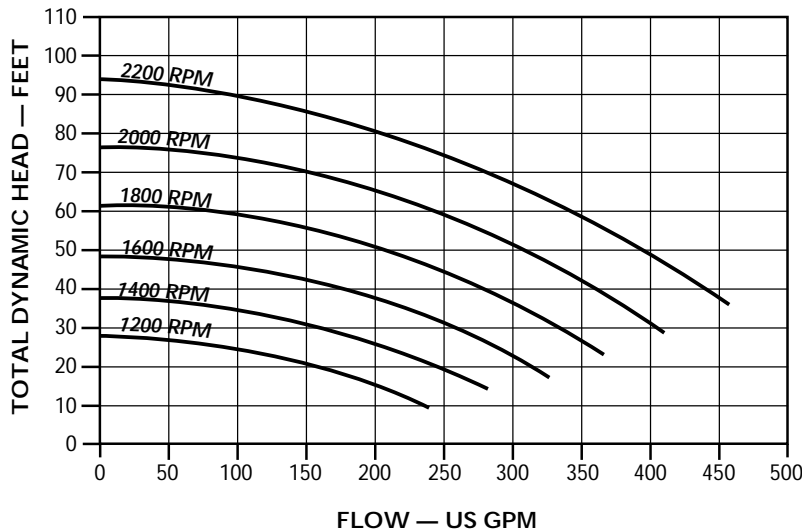

Performance Table

Diesel Set — John Deere 3009D, 14.0 hp @ 2200 rpm
 Impeller Diameter — 7 1/2 inches (171 mm)

Total Suction Head — Feet	Total Delivery Head — Feet				
	10	15	20	25	30
10	450	435	430	415	400
15	440	430	425	410	385
20	410	385	350	315	290
25	370	330	300	280	255

Performance data listed in table and curves based on water tests at sea level and 68° F (20° C). Larger diameter pipes may be required for maximum flows.

Dimensions

CD80M — John Deere 3009D, GP30 Highway Trailer
 Weight: 1586 lbs.

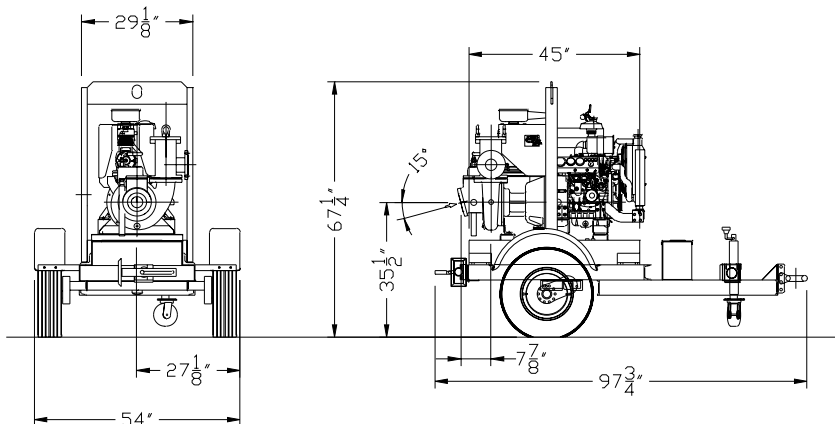

All dimensions listed in inches.

Specifications

- Maximum Operating Speed:**
2200 rpm
- Maximum Operating Temperature:**
+212° F (100° C)
- Maximum Working Pressure:**
41 psi
- Maximum Suction Pressure:**
29.0 psi
- Maximum Casing Pressure:**
61 psi
- Fuel Tank Capacity:**
30 gallons
- Fuel Consumption:**
0.84 gph
- Pipe Connections:**
3" ASA 150#
- Solids Handling:**
1-5/8" diameter

Materials

- Pump Casing, Suction Cover, Separation Tank and Wearplates:**
Close-grained cast iron
- Impeller:**
Cast chromium steel to minimum Brinell hardness, 341 HB
- Shaft:**
1-1/2% nickel/chromium steel
- NRV-Mushroom:**
High nitrile rubber
- Mechanical Seal Faces:**
Solid silicon carbide



One Floodgate Road, Bridgeport, NJ 08014
 Tel: (856) 467-3636 • Fax: (856) 467-4841
www.godwinpumps.com

BRANCH LOCATIONS:

Norwich, CT • Buffalo, NY • Chicago, IL
 Washington, DC • Richmond, VA • Virginia Beach, VA • Charleston, WV • N. Charleston, SC
 Atlanta, GA • Houston, TX • Raleigh, NC

Dri-Prime® is a registered trademark of Godwin Pumps of America, Inc.
 Specifications and illustrations are subject to revision without notice.
 © Copyright 2000 Godwin Pumps of America, Inc.