

GST05/10 Sub-Prime® Electric Submersible Trash Pumps

The GST Sub-Prime line is a selection of portable, electric submersible pumps designed for trash laden applications. Standard side discharge and semi-vortex cast iron impeller enable these units to handle up to 1" (25mm) diameter solids. And the fully removable volute makes clean-out fast and easy. The GST Sub-Prime line offers flow rates to 75 gpm (4.75 l/sec) and maximum heads to 48 feet (14.6 meters). Units are available in 0.5 hp / 0.4 kW (GST05) and 1 hp / 0.75 kW (GST10) models. Need versatility? High performance and affordability combine to make the GST Sub-Prime ideal for use in general dewatering applications as well. For automatic applications, a piggy back single float switch can be supplied.

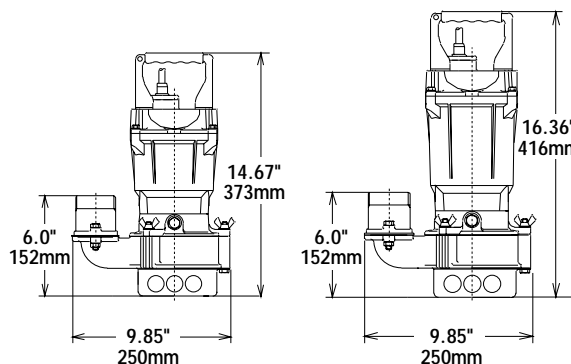

Features

- Solids handling up to 1" (25mm) in diameter
- Dry running capability without damage damage
- No control panel required
- Portable, lightweight, durable
- Side discharge design
- Non-wicking cable with strain relief
- High-torque, capacitor-start motor
- Motor thermal overload protection
- Silicon Carbide mechanical seal
- Triple seals — internal upper and lower mechanical seals and external lip seal
- Semi-vortex cast iron impeller
- Cast iron volute, fully removable for easy clean-out

Specifications Single-Phase Models

	GST05	GST10
HP/kW	0.5 HP/0.4 kW	1.0 HP/0.75 kW
Max. Flow	60 gpm (3.8 l/sec)	75 gpm (4.7 l/sec)
Max. Head	33' (10 meters)	48' (14.6 meters)
Max. Solids	1" (25mm)	1" (25mm)
Cable Length	30' (9 meters)	50' (15 meters)
Discharge Size	2" (50mm)	2" (50mm)
RPM	3600	3600
Max. Fluid Temp.	90° F (32° C)	90° F (32° C)
PH Range	6.5-8.0	6.5-8.0
Voltage	115, 230	115, 230
Amps	5.8, 2.9	10.3, 5.1
Phase	Single	Single
Height	14.67" (373mm)	16.36" (416mm)
Width	9.85" (250mm)	9.85" (250mm)
Weight	22 lbs. (10kg)	29 lbs. (13 kg)

GST Sub-Prime® Performance Curves

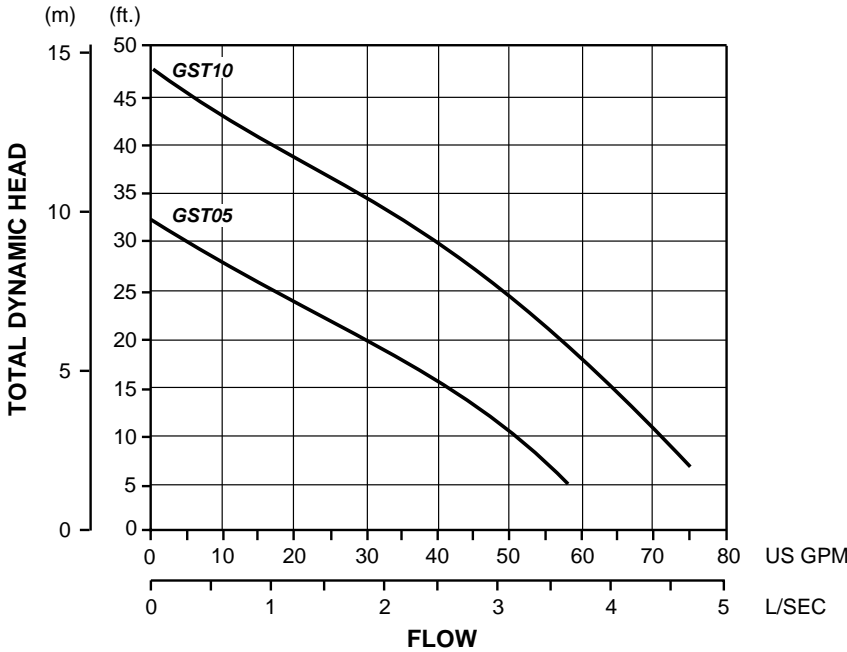

WARNING: Pumps are not designed for use in explosive atmosphere, flammable environments or for pumping volatile liquids.

Design & Construction

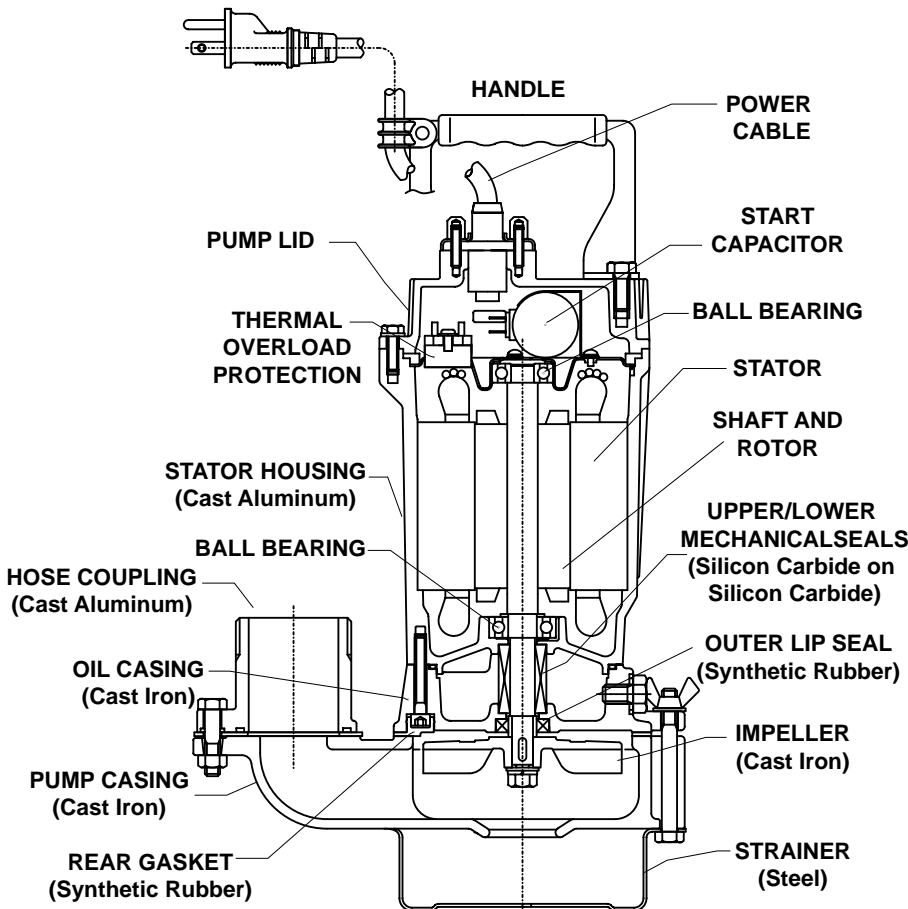

Float Switch

Optional Float Switches available for automatic, remote activation of Sub-Prime pumps. Package consists of 30'/50' (9M/15M) power cord with piggy-back power plug, variable length float tether, and sealed float. Typical configuration shown in the following.

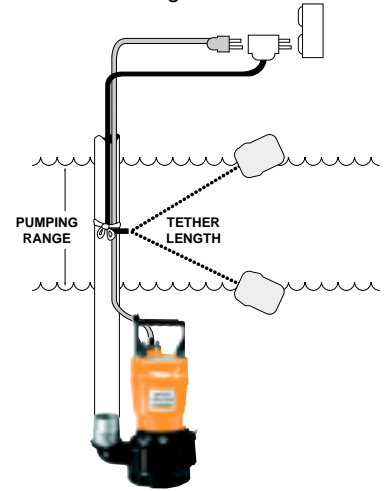

Pumping range determined by tether length according to the following guide.

Tether Length	3.5	5	7	9	11	13	15 (in.)
	89	127	178	229	279	330	381 (mm)
Pumping Range	6.5	7.5	8.5	10	11	12.5	13.5 (in.)
	165	191	216	254	279	318	343 (mm)

Pumping range based on operation in non-turbulent conditions. Actual range may vary due to temperature conditions and cord shape. Tether length increases variance of pumping range.

godwin
pumps

One Floodgate Road, Bridgeport, NJ 08014, USA
(856) 467-3636 • Fax: (856) 467-4841

Quenington, Cirencester, Glos., GL7 5BX, UK
+44 (0)1285 750271 • Fax: +44 (0)1285 750352

E-mail: sales@godwinpumps.com
www.godwinpumps.com

BRANCH LOCATIONS:

Norwich, CT • Buffalo, NY • Chicago, IL
Washington, DC • Richmond, VA • Virginia Beach, VA
Charleston, WV • Raleigh, NC • Charlotte, NC
N. Charleston, SC • Atlanta, GA • Houston, TX
San Antonio, TX • Helena, MT • Los Angeles, CA

Sub-Prime® is a registered trademark of Godwin Pumps of America, Inc. Specifications and illustrations are subject to revision without notice.
© Copyright 2002 Godwin Pumps of America, Inc.