

HL10M Dri-Prime® Pumps

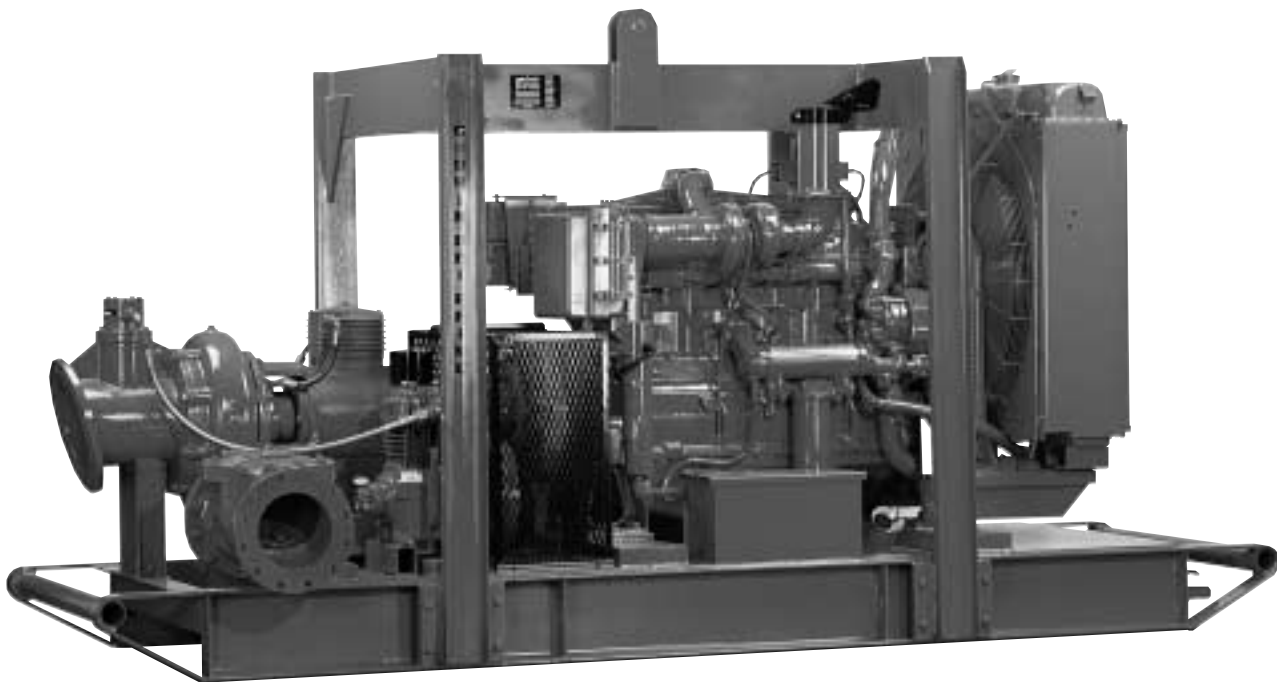

The Godwin Dri-Prime® 12" x 10" HL10M is a heavy duty, fully automatic self-priming pump specifically offered for pumping under discharge pressure conditions or high discharge lift applications. The HL10M offers flowrates up to 4,500 gpm, total dynamic heads up to 390 feet, and solids handling up to 3" in diameter. Like all Godwin pumps, the HL10M includes the patented Dri-Prime® air ejector priming system for fully automatic priming up to 28 feet of static suction lift.

Features

- Fully automatic priming from dry to 28 feet of suction lift. Maximum heads to 390 feet. Maximum flows to 4,500 gpm.
- Handles sludges and solids-laden liquids with solids up to 3" in diameter.
- Continuously operated venturi air ejector priming system operated by belt-driven air compressor requiring no form of periodic adjustment or operator intervention.
- Dual, high pressure, dry running solid silicon carbide inboard and carbon/stainless outboard mechanical seal with self-contained water/glycol circulating thermo-siphoning cooling.
- Mounted to a structural steel skid with integral 140/250 gal. fuel tank and lifting bail.
- Standard engine — Caterpillar 3406B diesel. Other engines available. Electric drive version also available.

HL10M Performance Curve

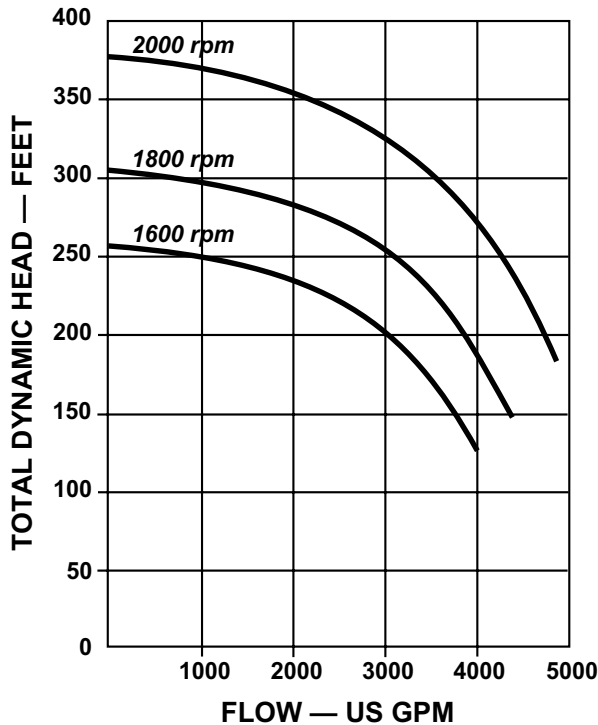

HL10M Performance Table

Diesel Set — Caterpillar 3406B, 400 hp @ 2000 rpm
 Impeller Diameter: 16.5" (420 mm)

Total Delivery Head — Feet

Total Suction Head — Feet	150	200	250	275
	Output — GPM			
15	4400	3900	3050	2500
20	3150	3050	2550	2500
25	2650	2450	2050	1850

Performance data listed in table and curves based on water test at sea level and 68° F (20° C). Maximum flows may require larger diameter pipes.

Dimensions

HL10M — Caterpillar 3406B, Skid Base

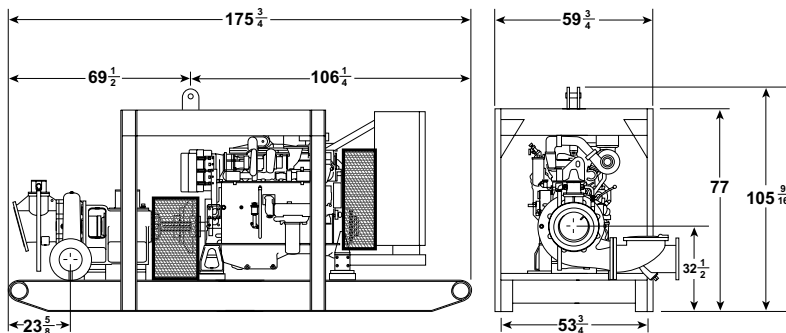

All dimensions listed in inches.

Specifications

- Maximum Operating Speed: 2000 rpm
- Maximum Operating Temperature: 194° F (90° C)
- Maximum Working Pressure: 155 psi
- Maximum Suction Pressure: 90 psi
- Maximum Casing Pressure: 240 psi
- Fuel Tank Capacity: 140/250 gal.
- Fuel Consumption: 19.7 gph
- Pipe Connections: Suction: 12" ASA 150
Discharge: 10" ASA 150
- Solids Handling: 3" dia.

Materials

- Pump Casing, Bearing Casing, & Non Return Valve: Close grained cast iron
- Impeller: Cast chromium steel, hardened to minimum Brinell 293 HB
- Wearplates: Nickel-Chrome cast iron, replaceable
- Mechanical Seal: Solid silicon carbide faced, dry running, dual high pressure mechanical seal cooled by glycol/water mix from integral tank



One Floodgate Road, Bridgeport, NJ 08014
 Tel: (856) 467-3636 • Fax: (856) 467-4841
 www.godwinpumps.com

BRANCH LOCATIONS:

- Norwich, CT • Buffalo, NY • Chicago, IL
- Washington, DC • Richmond, VA • Virginia Beach, VA • Charleston, WV • N. Charleston, SC
- Atlanta, GA • Houston, TX • Raleigh, NC

Dri-Prime® is a registered trademark of Godwin Pumps of America, Inc. Specifications and illustrations are subject to revision without notice. © Copyright 2000. Godwin Pumps of America, Inc.