

# HL5MS Dri-Prime® Pumps

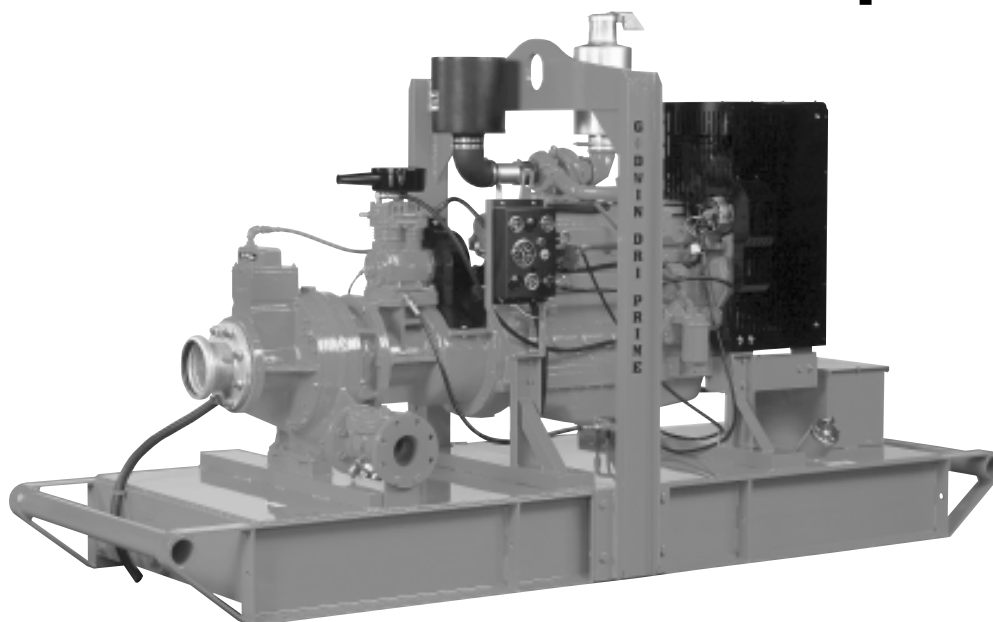

The Godwin Dri-Prime 6" x 4" HL5MS automatic priming centrifugal pump is a compact, high pressure pump perfectly suited for temporary pumping under discharge pressure conditions or high discharge lifts. Capable of generating maximum flows of 1000 gallons per minute and discharge heads to 455 feet or 195 psi, the HL5MS is used in temporary fire service, quarry and mine dewatering, and as a temporary replacement for permanently installed transfer pumps. Like all Godwin Dri-Prime pumps, the HL5MS can prime and reprime automatically from dry to 28 feet of suction lift.

## Features

- Fully automatic priming from dry to 28 feet of suction lift. Maximum heads to 455 feet, maximum flows to 1000 gpm.
- Pumpend available in cast iron, stainless steel and other hardened materials.
- Extensive application flexibility — will handle sludge with solids up to 1-3/8" in diameter.
- Continuously operated "Godwin" patented venturi air ejector priming device featuring direct drive air compressor requiring no form of periodic adjustment or control.
- Dry running, oil-lubricated, mechanical seal with high abrasion resistant silicon carbide interfaces.
- Solids handling swing-type Non Return valve with renewable flexible rubber seat.
- Compact unit mounted on a heavy-duty skid base or two-wheeled highway trailer both incorporating integral overnight running fuel tank and lifting frame.
- Simple maintenance — normally limited to checking engine and seal cavity oil levels.
- Standard John Deere 6068T or Caterpillar 3116TA engine. Also available with other diesel engines or electric drive motor.
- Low-profile side discharge for easy pipe connection.

godwin  
pumps



# HL5MS Performance Curve

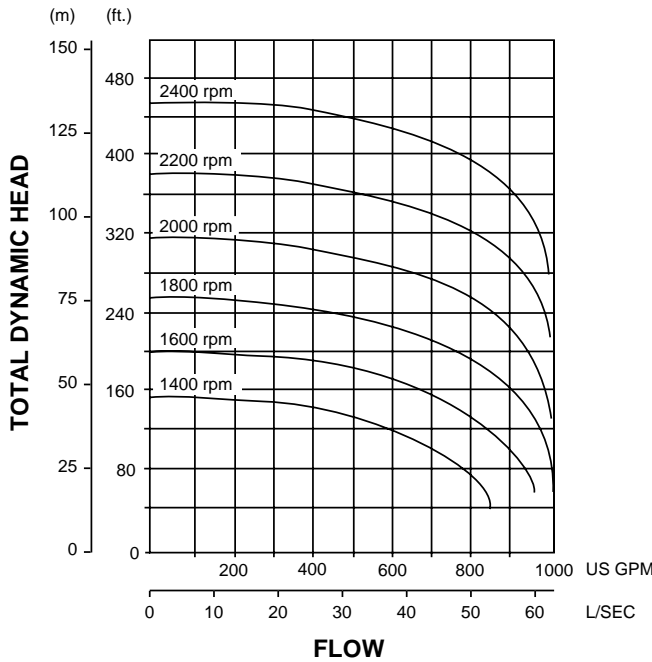

## HL5MS Performance Table

Diesel Set: John Deere 6068T, 151 hp @ 2400 rpm  
 Caterpillar 3116TA, 150 hp @ 2400 rpm  
 Impeller Diameter – 14-9/16 inches (370 mm)

Total Suction Head Feet	Total Delivery Head – Feet				
	150	200	250	300	350
10	1000	995	983	972	903
15	990	980	967	950	880
20	875	867	856	831	746
25	760	755	745	702	634

Performance data listed in table and curves based on water tests at sea level and 68° F (20° C). Larger diameter pipes may be required for maximum flows.

## Dimensions

HL5MS – shown with John Deere 6068T, Skid Base  
 Weight: 4780 lbs.

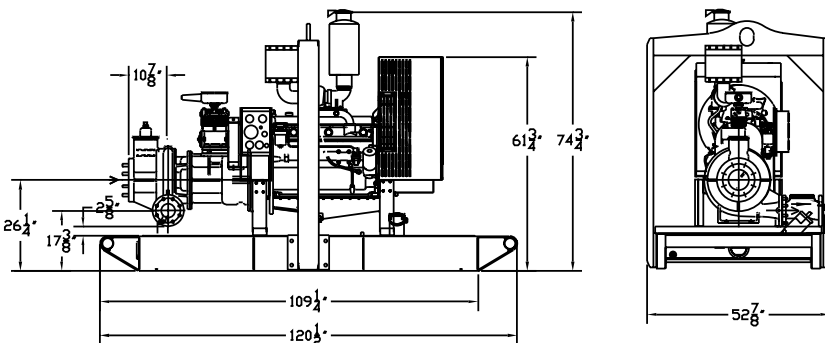

All dimensions listed in inches.

## Specifications

- Maximum Operating Speed:** 2400 rpm
- Maximum Operating Temperature:** +212°F (100°C)
- Maximum Working Pressure:** 197 psi
- Maximum Suction Pressure:** 88 psi
- Maximum Casing Pressure:** 296 psi
- Fuel Tank Capacity:** 105 to 175 gallons
- Fuel Consumption:** John Deere 6068T: 7.8 gph  
Caterpillar 3116TA: 8.3 gph
- Pipe Connections:** Suction: 6" ASA 150#  
Discharge: 4" ASA 150#
- Solids Handling:** 1-3/8" diameter

## Materials

- Pump Casing, Separation Tank and Non Return Casing:** Close-Grained Cast Iron
- Impeller:** Cast Chromium Steel
- Shaft:** 1-1/2% Nickel/Chromium Steel
- Wearplates:** Close Grained Cast Iron (optional 26% Chrome/Iron available)
- Non Return Valve Flapper:** High Nitrile Rubber
- Mechanical Seal Faces:** Solid Silicon Carbide



One Floodgate Road, Bridgeport, NJ 08014  
 Tel: (856) 467-3636 • Fax: (856) 467-4841  
 E-mail: sales@godwinpumps.com  
 www.godwinpumps.com

### BRANCH LOCATIONS:

- Norwich, CT • Buffalo, NY • Chicago, IL
- Washington, DC • Richmond, VA • Virginia Beach, VA
- Charleston, WV • N. Charleston, SC
- Atlanta, GA • Houston, TX • Raleigh, NC

Dri-Prime® is a registered trademark of Godwin Pumps of America, Inc. Specifications and illustrations are subject to revision without notice.  
 © Copyright 2001 Godwin Pumps of America, Inc. All rights reserved.  
 GPASL.052.601